

YORK RIVER YACHT CLUB

2015 Race Rules and Guidelines



RACE FLAG SIGNALS

Postponement / Stand-By (AP Flag)

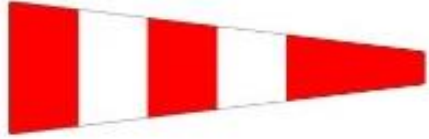

Starting Line & Finish Line Limit



Yellow Fleet Warning

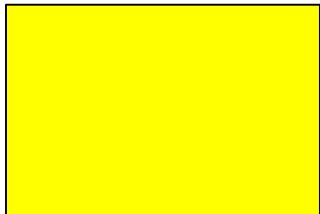

Blue Fleet Warning



Preparatory ('P' Flag)

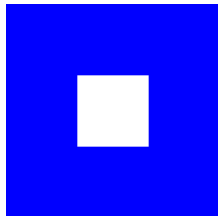

Individual Recall ('X' Flag)

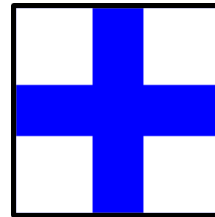

General Recall ('First Substitute' Flag)

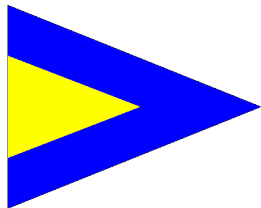

Shortened Course ('S' Flag)

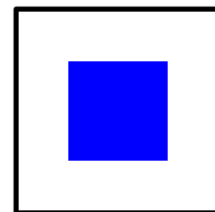

Abandon Race ('N' Flag)

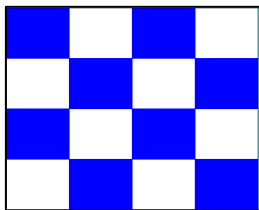

YORK RIVER YACHT CLUB
RACE RULES AND GUIDELINES for 2015
Table of Contents

I. GENERAL RACING INFORMATION	1
YRYC POINTS OF CONTACT	1
ELIGIBILITY	1
SAFETY	1
ENTRY PROCEDURE AND FEE	2
HANDICAP SYSTEM	2
MINIMUM RACE REQUIREMENTS & TIME LIMIT	3
SCORING	4
THROWOUTS	4
TIES	4
RULINGS	5
PROTESTS	5
AWARDS AND AWARDS ELIGIBILITY	6
II. RACE COMMITTEE INSTRUCTIONS	9
<u>STEP 1: SELECT RACE COURSES</u>	9
<u>STEP 2: ESTABLISH A STARTING LINE</u>	10
<u>STEP 3: RUN THE STARTING SEQUENCE</u>	11
<i>Problems at the Start</i>	12
Some Boats Over Early, Individual Recall	12
All or Most Boats Over Early -- General Recall	12
Postponement	13
Abandonment	13
<u>STEP 4: ESTABLISH A FINISH LINE</u>	13
<u>STEP 5: HOW TO SHORTEN THE COURSE AFTER THE START</u>	13
<u>STEP 6: RECORD FINISH TIMES</u>	14
III. SAILING INSTRUCTIONS	15
WEDNESDAY NIGHT SERIES	15
<i>Race Format and Schedule</i>	15
<i>Racing Classes</i>	15
<i>Starting Sequence</i>	15
FROSTBITE SERIES	16
<i>Race Format and Schedule</i>	16
<i>Racing Classes</i>	16
<i>Starting Sequence</i>	16
YRYC SPECIAL RACES	17
<i>Race Format and Schedule</i>	17
<i>Starting Sequence</i>	17
IV. YRYC RACE COURSES	19
APPENDIX A: PROTEST FORM	37
APPENDIX B: RACE ENTRY FORMS	39
APPENDIX C: YRYC 2015 RACE SCHEDULE	41

YORK RIVER YACHT CLUB

2015 RACE RULES AND GUIDELINES

I. GENERAL RACING INFORMATION

YRYC Points of Contact

There is a continually updated **YRYC Web Site** that will be used to post race information, cancellations, schedules, announcements, and results. Please refer often to **www.yryc.org** for this and other pertinent racing and York River Yacht Club information.

Commodore: Joran Gendell 757-777-5002 jorankyn@yahoo.com

Race Captain: Brian Gregory 804-642-9157 britishhornet@cox.net

Race Committee: Steve Bowen 757-869-7830 sbowen@printpack.com
 Dan Fox 757-759-1967 foxbd@cox.net
 Mike Mastracci 757-771-8003 mmastracci@cox.net

Eligibility

Any monohull boat that meets *PHRF of The Chesapeake, Inc. Minimum Equipment and Accommodation Standards, Category 6P*, may compete in YRYC Wednesday Night Series and Frostbite Spinnaker Series Races.

Certain YRYC Special Races may allow participation by other types of boats. Refer to the Sailing Instructions for a particular race for further information.

Participation in the Wednesday Night Series requires YRYC membership. A non-member may race a boat with the YRYC Fleet for one series (spring, summer, fall or Frostbite) but then must apply for YRYC membership to continue racing.

All boats participating in the Wednesday Night Series must take at least one turn as Race Committee (RC). It is expected that any boat whose RC date was cancelled will be RC for the makeup race in the same series. If there is more than one cancellation in a series, the boat that will perform RC duty in the makeup race will be decided by a coin toss.

Safety

In general, unless the Race Captain or a designee deems weather conditions to be dangerous at or just prior to race time, races will go on as scheduled. Examples of dangerous conditions are active or imminent electrical storms in the racing area, or sustained winds higher than 20 knots. Watch for announcements on the YRYC web site.

Should conditions require a late decision to cancel, the Race Captain will attempt to reach registered skippers by phone.

If the 'Y' flag is posted on the Committee Boat, all participants *must* wear a USCG-approved PFD *at all times* during that race.

All boats participating in YRYC races should monitor VHF Channel 72 while racing. This is the working channel for the YRYC Race Committee Boat.

Entry Procedure and Fee

A competitor must submit a completed CBYRA or YRYC Race Entry Form (included at the end of this book) and the appropriate entry fee prior to competing in any YRYC race. Entries may be mailed to the Race Captain or dropped off in the Race Captain's box located in the YRYC Clubroom.

The entry fee schedule is as follows:

Races Included	Fee
All Wednesday Night Series, YRYC Special Races (excl. YR Cup), & Frostbite Series	\$75

Handicap System

PHRF of the Chesapeake, Inc. handicap ratings will be used for all boats participating in YRYC Races. Participants are strongly encouraged to obtain a current PHRF certificate based on actual sail and boat measurements. PHRF rating application forms may be downloaded from the PHRF of the Chesapeake web site. A current PHRF certificate is required for sanctioned races such as the York River Cup, Admiral's Cup, Leukemia Cup, Moonlight Race and SBRW. Note that PHRF issues separate handicaps for spinnaker and non-spinnaker fleets.

Adjustments Based on Boat Configuration

Any boat competing in the Wednesday Night Series may request that a handicap rating be assigned by the YRYC Race Committee that reflects the condition of the boat when presented for racing. A YRYC handicap rating may account for the boat's propeller configuration, largest headsail size, and/or roller furling gear. Competitors must submit a *YRYC Wednesday Night Race Entry Form* and contact the YRYC Race Captain before being considered for a YRYC handicap adjustment.

For boats racing in the YRYC Wednesday Night Series, the following adjustments may be applied by the Race Committee to the standard boat base handicap published by PHRF of the Chesapeake, Inc.

- a. Propeller Configuration

- i. Fixed two-bladed prop - Add 6 seconds to base PHRF rating.
 - ii. Fixed three-bladed prop - Add 9 seconds to base PHRF rating.
- b. Largest Headsail Size
- i. Under 140% - Add 6 seconds to PHRF rating.
 - ii. 141% to 148% - Add 3 seconds to PHRF rating.
 - iii. 149% to 155% - No point adjustment.
 - iv. 156% to 164% - Subtract 3 seconds from PHRF rating.
 - v. 165% to 170% - Subtract 6 seconds from PHRF rating.
 - vi. Over 170% - To be assigned by Race Captain.
- c. Headsail Roller Furling System
- Furling Drum above deck - Add 6 seconds to PHRF rating. The furling sail must have a proper UV cover as defined by PHRF.

Blue (Non-Spinnaker) Fleet

The Blue Fleet will be non-spinnaker only. No “gennakers”, “drifters”, or other lightweight headsails will be allowed. Handicap ratings will be based on either the boat’s PHRF NS rating, or the boat’s PHRF spinnaker rating with the above allowances applied.

Yellow (Spinnaker) Fleet

The Spinnaker Fleet will allow the use of spinnakers and other lightweight headsails. PHRF spinnaker handicap ratings will be used. Boats without current PHRF certificates will be assigned a rating by the Race Captain, based on published PHRF of the Chesapeake ratings (or other regions if necessary), with the above allowances for headsail/prop configuration as appropriate.

Limitations on Headsails

A whisker pole, when used with a headsail, must be attached to the forward part of the mainmast and its length may not exceed the boat’s ‘J’ measurement. Double headsails are not allowed except when the boat is rigged as a cutter.

Minimum Race Requirements & Time Limit

To constitute an official YRYC race there must be:

1. A minimum of three competing boats (per fleet) in the vicinity of the starting line showing the intent to race during the starting sequence.
2. A minimum of one boat making a proper finish within the designated time limit.

The time limit for all YRYC races, unless modified by the Sailing Instructions for a specific race, is **two hours**.

The Committee Boat, at its crew’s discretion, may abandon its post at any time after the stated time limit. Boats still wishing to be scored shall record their time of finish and report it to the Race Committee at the first reasonable opportunity. Boats doing so shall pass

within two boat lengths of the finishing mark, and record their finish time to the nearest second using GPS time.

Scoring

Finishing places for an individual race will be determined per current PHRF of the Chesapeake recommendations, calculated using valid or assigned boat handicaps as described above and incorporating time-on-time corrections adjusted for wind conditions.

Wednesday Night and Frostbite Series

Points will be scored using the “Low Point” system according to *USSA RRS Appendix A4*, with the following exceptions:

- a. Yachts starting, but scored as DNF, will score the average of points awarded to all DNF boats assuming all had finished and none had tied. The average will be rounded down to the nearest whole number. For example, if seven boats start and four score DNF, then the four DNF boats will all receive a score of $(4+5+6+7)/4=5.5$. This result rounds down to 5.
- b. Yachts registered for a series, but scored as DNC or DNS, will score one point more than the number of boats starting that race.
- c. A registered racer serving as Committee Boat will be scored as follows: the average of all scores for the series, excluding throwouts, rounded down to the nearest whole number. Example: individual scores for a series are 2,3,6,(RC),2,3. 6 is the throwout, average of the remainder is 2.5, therefore score for RC duty is 2.

DNF – Did Not Finish

DNC – Did Not Compete (did not come to the starting area)

DNS – Did not start (other than DNC)

Special Races

Points will be scored using the “Low Point” system according to *USSA RRS Appendix A4*.

Throwouts

Throwout races in a Wednesday Night or Frostbite Series will be allowed as follows, according to the number of races completed in that series:

- 5 or fewer races completed: no throwouts
- 6 races completed: 1 throwout
- 7 or more races completed: 2 throwouts

Ties

Individual race ties will be scored in accordance with *USSA RRS Appendix A7*.

Series ties will be broken in accordance with *USSA RRS Appendix A8*, except as follows:

- If a tied series score includes calculated scores from Race Committee duty, the tie will be broken by considering only scores from races where the tied boats competed against each other head-to-head, with no throwouts.
- If the series scores are still tied, the tie will be broken in accordance with *USSA RRS Appendix A8* using only the head-to-head scores with no throwouts.

Rulings

York River Yacht Club will follow US Sailing and CBYRA rules unless specifically modified as stated in this book or in the Sailing Instructions for a particular race.

The Race Captain, solely or in conjunction with an established Race Committee, shall interpret the *US Sailing Racing Rules of Sailing* (USSA RRS) and the *YRYC Race Rules and Guidelines* (RRG) in effect at the time of the race in the spirit in which they are intended.

The Committee Boat Crew will make the determination on starting or finish line fouls of:

- Over the starting line early (OCS)
- Started or finished outside the prescribed start/finish line (DNS, DNF)
- Did not break the plane of the finish line before withdrawing from the race (DNF)

Protests

Protests are discouraged, but if you feel you *must* protest, the following procedure shall be followed in its entirety:

1. The protester must hail the protested boat at the time of the infraction, indicating the intent to file a protest. Proper protocol calls for the protester to indicate the nature of the alleged foul, in order to give the protested boat opportunity to purge the foul (720 degree turns or 20% penalty) if she chooses.
2. A protest flag (a red rectangular flag) must be flown from the backstay of the protesting boat at the first safe opportunity after the alleged foul. The flag must remain flying and readily visible for the remainder of the race.
3. The protester must verbally notify the Committee Boat of the intent to file a protest at the earliest reasonable opportunity or upon finishing the race.
4. The Committee Boat will advise the Race Captain that a protest has been lodged and the Race Captain or other designated member of the Race Committee will be available after the race to hear the protest. A formal protest must be filed with a Race Committee member not more than one hour after the protesting boat's finish. The protest must be presented *in writing* using a CBYRA Protest Form (included at the back of this book). The RC member who hears the protest may rule immediately or may take the evidence under advisement for further review/investigation.
5. The protester must state the rule or rules under which the protest is made. The Race Committee will not provide a copy of the *USSA Racing Rules of Sailing*.

Failure to meet all of the above conditions will cause the protest to be rejected by the Race Committee without discussion and without recourse.

Awards and Awards Eligibility

Wednesday Night Individual Series

To be eligible for Wednesday Night Individual Series awards, a boat must be properly registered and have competed in at least four of the scheduled races in a series. "Competing" is defined as making a proper start or serving as Committee Boat in said four races. Individual Series awards will be given for each class. The number of awards for each class will be determined as follows:

- Three eligible boats – One award.
- Five eligible boats – Two awards.
- Seven eligible boats – Three awards.
- Nine eligible boats – Four awards.
- Eleven or more eligible boats – Five awards.

Wednesday Night Overall Season Awards

To be eligible for Wednesday Night Overall Season Awards, a boat must be properly registered and have competed in at least four of the scheduled races in all three Wednesday Night Series. "Competing" is defined as making a proper start or serving as Committee Boat in said four races. Overall Season Awards will be given for each class. The number of awards for each class will be determined as follows:

- Three eligible boats – One award.
- Five eligible boats – Two awards.
- Seven eligible boats – Three awards.
- Nine eligible boats – Four awards.
- Eleven or more eligible boats – Five awards.

Wednesday Night Season Championship

The Wednesday Night Season Champion is the boat that accumulates the lowest point total over the three Wednesday Night Series in the class with the greatest number of total starters over the course of the season. To be eligible for the Wednesday Night Season Championship a competitor must:

- i. be a member in good standing of the York River Yacht Club,
- ii. properly register and compete in at least four races in each of the three Wednesday Night Series (Spring, Summer and Fall).

Frostbite Series

To be eligible for Frostbite Series awards, a boat must be properly registered and have competed in at least four of the scheduled Frostbite Series races. "Competing" is

defined as making a proper start or serving as Committee Boat in said four races. The number of awards for each class will be determined as follows:

- Three eligible boats – One award.
- Five eligible boats – Two awards.
- Seven eligible boats – Three awards.
- Nine eligible boats – Four awards.
- Eleven or more eligible boats – Five awards.

In addition to individual awards, a plaque will be added to the permanent clubhouse trophy for the Frostbite Series. The plaque will note the year, boat, and skipper/owner's name.

Special Races

To be eligible for a Special Race award, a boat must be properly registered. The number of awards for each class will be determined as follows:

- Three eligible boats – One award.
- Four or five eligible boats – Two awards.
- Six or seven eligible boats – Three awards.
- Eight or nine eligible boats – Four awards.
- Ten or more eligible boats – Five awards.

In addition to individual awards, a plaque will be added to permanent clubhouse trophies for the Single Handed Race. The plaque will note the year, boat, and skipper/owner's name.

II. RACE COMMITTEE INSTRUCTIONS

Notes:

- Spring Series Starts at “R24” • Summer and Frostbite Series Start at “R22”
- Fall Series Starts at “R22” for the first two races then moves to “R24”
- The Race Committee should plan to arrive in the starting area at least thirty minutes before the first scheduled start.
- Summer and Frostbite courses which include mark R “4” should not be chosen if the 2-hour time limit for the race cannot be completed within the time span between 2.5 hours before and 2.5 hours after high tide (due to shallow water near R”4”).

Step 1: Select Race Courses

Select racecourses that are appropriate for the weather conditions, with particular consideration given to wind direction and strength. Ideally, courses should be selected that provide a start to windward, but certain wind conditions may require an off-wind start. The wind strength should be used to help select courses of appropriate length that can be completed within the time limit. Different courses may be selected for the Blue and Yellow Fleets, and both should be indicated on the course board. An “s” after the course number in the tables below indicates that the course should be shortened to one lap. An asterisk (*) indicates a course that can be used in very light wind.

For **Spring Series and end of the Fall Series** races, use the following table to select racecourses. Course numbers refer to courses defined in Section IV.

		Wind Direction							
		N	NE	E	SE	S	SW	W	NW
Wind Speed	< 10kts	13	2s, 15	3, 16s*	4, 5, 16s*	16s*	7	8s	1, 11s, 12
	> 10kts	14	2	12, 16	4, 5	6, 16	7	8	1, 11, 12

Race Course Selection – Spring Series and end of the Fall Series

For **Summer, beginning of Fall, and Frostbite Series** races, use the following table to select racecourses. Course numbers refer to courses defined in Section IV.

		Wind Direction							
		N	NE	E	SE	S	SW	W	NW
Wind Speed	< 10kts	1s	2s, 3s, 4s	3s, 7s, 14s*	10, 14s*	12s, 13, 14s*	4s, 16s	7s	18
	> 10kts	1	2, 3, 4, 5	3, 5, 6, 7, 14	8, 9, 14	11, 12	4, 14, 15, 16	7	17

Race Course Selection – Summer, beginning of Fall, and Frostbite Series

Once the racecourses have been selected, the course numbers should be displayed on the race course board hung from the railing on the non-starting line side of the Committee Boat. The cloth course numbers or dry-erase markers are kept in the RC equipment bag.

Step 2: Establish a Starting Line

The starting line is an imaginary line between a fixed mark or buoy (R"24" or R"22", in our case) and an orange flag affixed to the starting line side of the Committee Boat.

The Committee Boat should anchor approximately 100 yards from York River R"24" or R"22", in a position that creates a starting line perpendicular to the wind direction with the Committee Boat at one end of the line. This can be accomplished as follows:

- 1.) Motor to a position that is some distance directly downwind and approximately 100 yards (10-15 boatlengths) to one side of R"24" or R"22" with your boat pointing into the wind. Refer to the course diagrams for the proper position of the Committee Boat at the start of the race.
- 2.) Motor slowly straight into the wind and bring R"24" or R"22" directly abeam and approximately 100 yards away. This is where the boat should end up after the anchor is set.
- 3.) Be aware of any current, and continue to motor slowly into the wind for about another 100 feet (about 1 minute at 1 knot). Stop the boat and drop your anchor at this spot.

- 4.) Drift downwind (or motor in reverse) and let out about 105 feet of anchor rode. Set the hook. This will place the boat back at the spot where R"24" or R"22" is directly abeam and 100 yards away when you are pointed into the wind. See Figure 1. Strong current may require some adjustment!

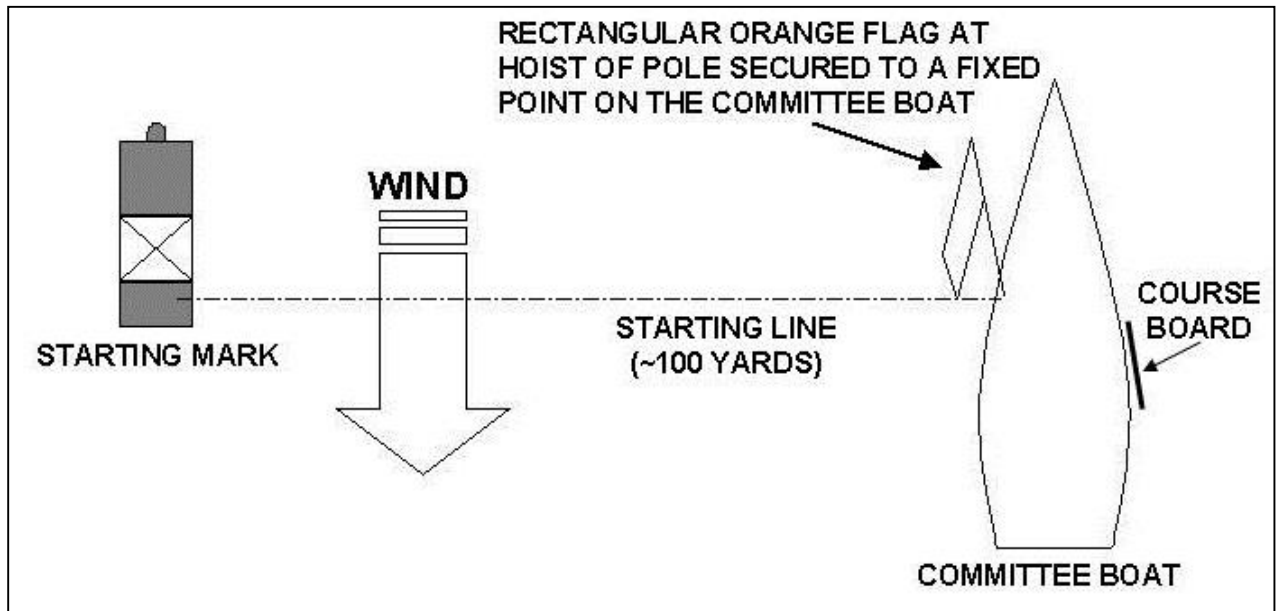

Figure 1. Starting Line Diagram.

Step 3: Run the Starting Sequence

Sound signals should be made with an air horn, but in its absence a whistle may be used. Voice (shouted or transmitted on VHF 72) is the last choice. Start the race without sound signals if no sound signals are available.

Visual signals (see the 'Race Signals' page at the front of this book) should be raised and lowered quickly and deliberately to facilitate accurate setting of race timers by the competitors. The person raising and lowering the signals should be on the Committee Boat's foredeck so that the signals are clearly visible to all competitors.

It is suggested that the Committee Boat fly the 'AP' flag (postponement) until ready to begin the starting sequence for the first class. When the "AP" flag is raised two short blasts should sound. One minute before giving the first warning signal, remove the 'AP' flag and sound one long blast.

The visual and audible signal sequence for the start is as follows:

Warning - Five (5) minutes before the start of each class:

The Committee Boat raises the class flag for the class that is about to start.

OPTION: A single short sound blast in addition to the flag.

NOTE: The flag, not the sound, is the official signal.

Preparatory - Four (4) minutes before the start of each class:

The Committee Boat raises the 'P' preparatory flag. The flag of the class that is starting remains flying.

OPTION: A single short sound blast in addition to the flag.

NOTE: The flag, not the sound, is the official signal.

One-minute - One (1) minute before the start of each class:

The Committee Boat removes the 'P' preparatory flag. The flag of the class that is starting remains flying.

OPTION: A single long sound blast in addition to the flag.

NOTE: The flag, not the sound, is the official signal.

Starting – At the start of each class:

The Committee Boat removes the class flag.

OPTION: A single short sound blast in addition to the flag.

NOTE: The flag, not the sound, is the official signal.

The Committee Boat should simultaneously lower the flag for the starting class and raise the flag for the next class to start, signaling five minutes to the start for the next class. Thus, the Starting Signal is also the Warning Signal for the next class to start.

Problems at the Start

Some Boats Over Early, Individual Recall

If some boats are over early, promptly display the 'X' flag accompanied by one long sound blast. The Committee Boat may also attempt to hail such boat(s) on VHF channel 72. Code flag "X" comes down when all boats over early have returned properly (completely behind the starting line). Code flag "X" comes down with the preparatory signal if all boats over early have not properly returned for that class.

All or Most Boats Over Early -- General Recall

If all or most boats are over early, promptly display the 'first substitute' flag accompanied by two long sound blasts.

Display the Warning Signal for a new start for the recalled class one minute after removing the 'first substitute' flag accompanied by a short sound blast. The starts for any succeeding classes should then follow this new start.

Postponement

The Committee Boat may delay or postpone a start for any reason and at any time within the starting sequence. Display the 'AP' flag accompanied by two sound blasts.

To resume, remove the 'AP' flag accompanied by one sound blast. One minute later, give the 5-minute Warning Signal for the class that was starting when the postponement occurred.

Abandonment

The Committee Boat may abandon the race at any time by displaying the 'N' flag accompanied by three horn blasts (VHF 72 broadcast also highly recommended).

Step 4: Establish a Finish Line

Many racecourses require the Committee Boat to reposition after the starting sequence is completed for all classes (see course diagrams) and the finish line should be perpendicular to the course from the last mark. The finish line should be approximately 4 boat lengths long.

The finish line is an imaginary line between a fixed mark or buoy (R"24" or R"22", in our case) and an orange flag affixed to the finish line side of the Committee Boat. A boat has "finished" when any part of her hull, crew or equipment (including sails) in normal position, crosses the finish line in the direction of the course from the last mark.

The Committee Boat should give a short sound blast (and record the finish time) when a competing boat breaks the plane of the finish line.

Step 5: How to Shorten the Course After the Start

Should it become necessary to shorten a racecourse (e.g., due to dying wind), the Committee Boat must signal the shortened course by flying the 'S' flag. Racers can cross the finish line (between the Committee Boat and the starting mark) after rounding the last turning mark of the shortened course, and in the direction of the most direct line from the last turning mark. The Committee Boat should move perpendicular to the line from the last turning mark.

The Committee Boat can signal a shortened course for a particular class or classes by flying the 'S' flag along with the flag(s) of the class(es) whose course is shortened.

If it becomes necessary to shorten the course to finish at a mark other than the starting mark, the Committee Boat must move to that mark and establish a finish line. The finish line will be between the mark and the Committee Boat, on the most direct line from the previous turning mark.

Step 6: Record Finish Times

A GPS receiver, or a digital timepiece set to GPS time, should be used to record finish times. Finish times are recorded as “Local Time of Day” to the nearest second. Record finish times on the score sheets provided in the RC equipment bag. Use only one timepiece to record the finishing times of all boats.

III. SAILING INSTRUCTIONS

WEDNESDAY NIGHT SERIES

Race Format and Schedule

Three series of seven races each, for a total of twenty-one races, are scheduled. Five races in each series will count toward the series and season trophies. A Practice Race will be held on the Wednesday following the seventh race of each series, unless that date must be used to make up for a cancelled race in that series.

A “Tune-up” race will be held on the Wednesday night preceding the first race of the Spring Series. See the Race Schedule at the back of this book for race dates.

Racing Classes

Wednesday Night Race boats will be divided into two classes:

- Yellow Fleet (spinnaker)
- Blue Fleet (non-spinnaker)

Note that a boat with a PHRF rating of less than 150 wishing to compete in the Blue Fleet is subject to Race Committee review for eligibility.

A boat will be scored in only one class per series, but may change classes between series. Changing classes between series will eliminate the boat from competition for the Wednesday Night Overall and Season Championships.

Starting Sequence

The Committee Boat will usually display the postponement flag ‘AP’ with two sound signals prior to the first warning signal. Removal of the ‘AP’ flag accompanied by one sound signal will indicate the intent to signal the first warning one minute later. Sound signals may be made by air horn, whistle, voice, or gun. The visual signal is official and sound signals are optional.

<u>Class</u>	<u>Time</u>	<u>Flag(s)</u>	<u>Sound</u>	<u>Signal</u>
	1800	AP up	Two blasts	Postponement
	1814	AP down	One blast	Start sequence in 1 min.
Yellow	1815	Yellow up	One blast	Warning
Yellow	1816	Yellow; ‘P’ up	One blast	Preparatory
Yellow	1819	Yellow; ‘P’ down	One long blast	One Minute
Yellow	1820	Yellow down/Blue up	One blast	Yellow Fleet Start
Blue	1821	Blue, ‘P’ up	One Blast	Preparatory
Blue	1824	Blue, ‘P’ down	One long blast	One Minute
Blue	1825	Blue down	One blast	Blue Fleet Start

Class flags will be distributed to skippers during race registration. These must be flown from the backstay during a race. A boat must keep clear of the starting area during the start of a class other than her own.

The Race Committee may attempt to notify boats that are over early on VHF 72.

FROSTBITE SERIES

Race Format and Schedule

The Frostbite Series will consist of at least six races. Committee Boat duties for this series will be shared equally among registered racers or “running starts” will be used if the fleet is small.

The Frostbite Series races will be held on the dates listed in the race schedule at the back of this book.

Racing Classes

There will be one class for the Frostbite Series that includes all participating boats. Spinnaker use is allowed, with a 20 sec/mile credit given to boats racing non-spinnaker.

Starting Sequence

The Committee Boat will usually display the postponement flag ‘AP’ before the first warning signal. Removal of the ‘AP’ flag accompanied by one sound signal will indicate the intent to signal the Warning one minute later.

Starting signals will be as follows:

<u>Time</u>	<u>flag(s)</u>	<u>signal</u>
1330	Yellow	Warning
1331	Yellow; ‘P’ up	Preparatory
1334	Yellow; ‘P’ down	One Minute
1335	Yellow down	Start

Alternately, a “running start” may be used where one competing boat (the designated RC) decides on a racecourse and informs the other boats. R22 and a drop mark (in lieu of an anchored committee boat) will be used to define the starting line. The designated RC will sound horn signals beginning at 6 minutes to the start, then at each minute up to and including the start, while she also starts along with the rest of the competitors.

YRYC SPECIAL RACES

Race Format and Schedule

Race to Cape Charles

This will be a pursuit race starting in the York River and finishing at Plantation Light on the Eastern Shore. The racers may then rendezvous at Cape Charles and spend the night, returning to the York River along with a YRYC cruising contingent. Refer to the YRYC Race Schedule for the date. Details will be provided in the Special Sailing Instructions available on the web site several weeks before the race. There will be a spinnaker and a non-spinnaker “cruising” class.

Single Handed Race

Only one person shall be aboard the boat. Participants are required to wear an approved PFD *at all times* during the race. Refer to the YRYC Race Schedule for the date. Details will be provided in the Special Sailing Instructions available on the web site several weeks before the race. This is a non-spinnaker race.

Moonlight Race

This race starts in the evening and finishes after dark, following a course that will take competitors out to York Spit Light and back. Winners of the Moonlight Race receive a John Dworak Memorial Trophy. Refer to the YRYC Race Schedule for the date. Details will be provided in the Special Sailing Instructions available on the web site several weeks before the race. There will be a spinnaker and a non-spinnaker class.

Starting Sequence

The *USSA RRS Rule 26* 5-minute starting sequence will be used for all YRYC Special Races. Refer to the Sailing Instructions above and on the YRYC website for warning signal times.

IV. YRYC RACE COURSES

YRYC sponsored races may use any of the following numbered courses or a course as properly described at the skippers meeting or in the Special Sailing Instructions for that race. All courses herein are located near the mouth of the York River.

Approximate GPS Positions of YRYC Standard Racing Marks

The names and positions of the marks that are used for YRYC races are shown in Table 2.

Mark Name	Latitude	Longitude
Mark "W" westernmost mooring buoy off Yorktown	37° 14.10' N	76° 30.12' W
"Quick Flash"	37° 13.58' N	76° 29.21' W
Sarah Creek R"2"	37° 14.77' N	76° 29.16' W
York River R"24"	37° 14.20' N	76° 28.01' W
Mark "A"	37° 13.61' N	76° 27.28' W
York River R"22"	37° 14.41' N	76° 25.64' W
Goodwin Thorofare "GT"	37° 13.67' N	76° 25.06' W
York River G"21"	37° 14.10' N	76° 24.83' W
Perrin River R"4"	37° 15.56' N	76° 24.51' W
Perrin River "PR"	37° 14.82' N	76° 23.51' W
York River R"20"	37° 15.04' N	76° 22.56' W
York River G"19"	37° 14.32' N	76° 22.44' W
York Spit Light	37° 12.58' N	76° 15.24' W

Table 2. YRYC Standard Racing Marks

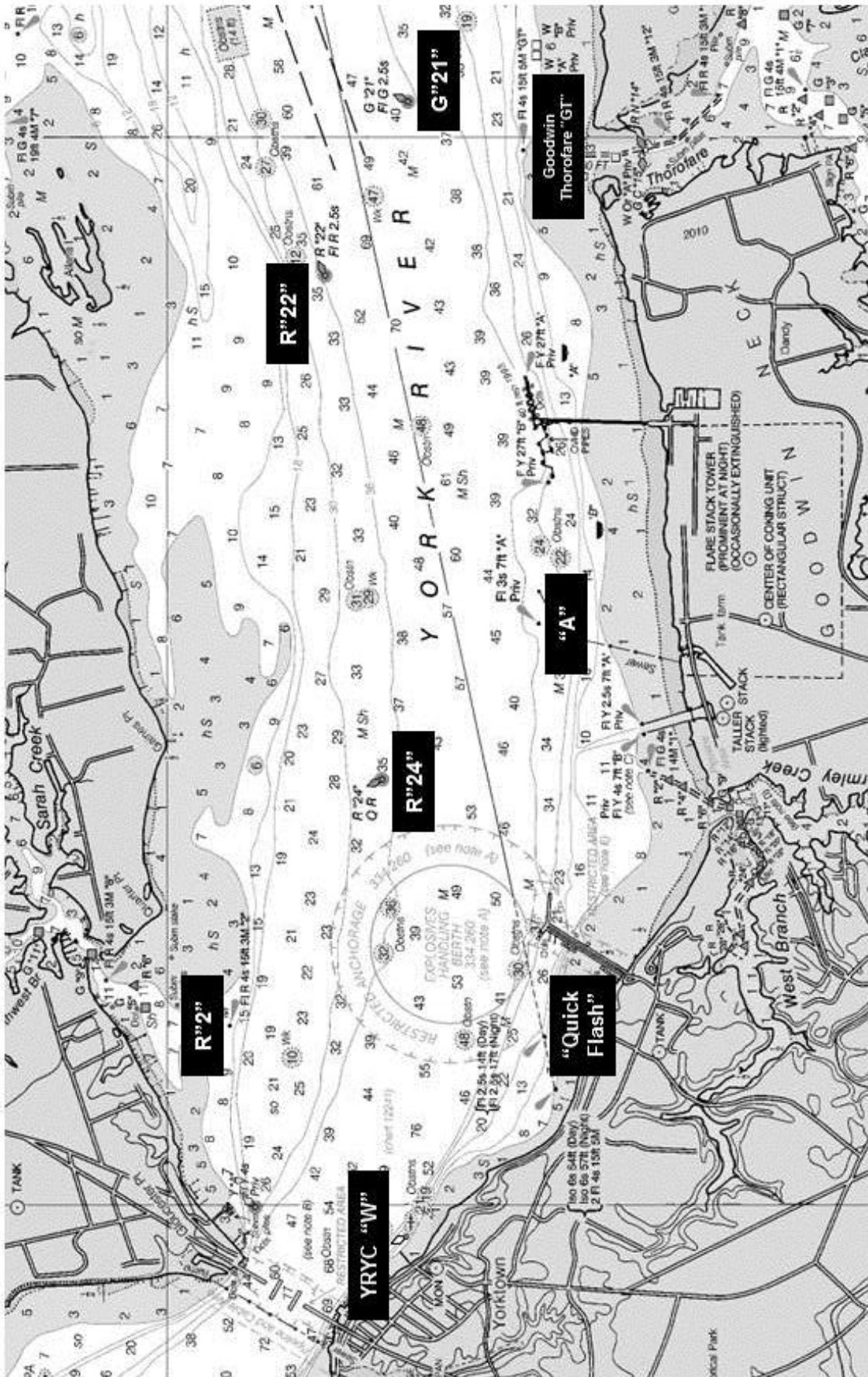

**YRYC Race Area Chart for SPRING and END
of FALL SERIES**

(NOT TO BE USED FOR NAVIGATION)

YRYC Course Descriptions: SPRING SERIES and end of FALL SERIES

COURSE #1 (Spring/Fall) (3.4 Nautical Miles)	DISTANCE	CUM DIST
Start at York River R"24"; to Sarah Creek R"2"	1.08	1.08
Sarah Creek R"2" to Port; to "Quick Flash"	1.18	2.26
"Quick Flash" to Port; to York River R"24"	1.14	3.40
Finish between R"24" and Committee Boat		

COURSE #2 (Spring/Fall) (7.6 Nautical Miles)	DISTANCE	CUM DIST
Start at York River R"24"; to York River R"22"	1.90	1.90
York River R"22" to Port; to York River R"24"	1.90	3.80
York River R"24" to Port; to York River R"22"	1.90	5.70
York River R"22" to Port; to York River R"24"	1.90	7.60
Finish between R"24" and Committee Boat		

COURSE #3 (Spring/Fall) (5.1 Nautical Miles)	DISTANCE	CUM DIST
Start at York River R"24"; to York River G"21"	2.54	2.54
York River G"21" to Port; to York River R"24"	2.54	5.08
Finish between R"24" and Committee Boat		

COURSE #4 (Spring/Fall) (4.8 Nautical Miles)	DISTANCE	CUM DIST
Start at York River R"24"; to Goodwin Thorofare "GT"	2.41	2.41
Goodwin Thorofare "GT" to Port; to York River R"24"	2.41	4.82
Finish between R"24" and Committee Boat		

COURSE #5 (Spring/Fall) (5.5 Nautical Miles)	DISTANCE	CUM DIST
Start at York River R"24"; to Mark "A"	0.83	0.83
Mark "A" to Stbd; to Sarah Creek R"2"	1.90	2.73
Sarah Creek R"2" to Stbd; to York River "24"	1.08	3.81
York River "24" to Stbd; to Mark "A"	0.83	4.64
Mark "A" to Stbd; to York River R"24"	0.83	5.47
Finish between R"24" and Committee Boat		

COURSE #6 (Spring/Fall) (5.8 Nautical Miles)	DISTANCE	CUM DIST
Start at York River R"24"; to Sarah Creek R"2"	1.08	1.08
Sarah Creek R"2" to Port; to "Quick Flash"	1.18	2.26
"Quick Flash" to Port; to Sarah Creek R"2"	1.18	3.44
Sarah Creek R"2" to Port; to "Quick Flash"	1.18	4.62
"Quick Flash" to Port; to York River R"24"	1.14	5.76
Finish between R"24" and Committee Boat		

YRYC Course Descriptions: SPRING SERIES and end of FALL SERIES

YRYC Course Descriptions: SPRING SERIES and end of FALL SERIES

COURSE #7 (Spring/Fall) (4.6 Nautical Miles)	DISTANCE	CUM DIST
Start at York River R"24"; to "Quick Flash"	1.14	1.14
"Quick Flash" to Port; to York River R"24"	1.14	2.28
York River R"24" to Port; to "Quick Flash"	1.14	3.42
"Quick Flash" to Port; to York River R"24"	1.14	4.56
Finish between R"24" and Committee Boat		

COURSE #8 (Spring/Fall) (6.8 Nautical Miles)	DISTANCE	CUM DIST
Start at York River R"24"; to YRYC Mark "W"	1.70	1.70
YRYC Mark "W" to Port; to York River R"24"	1.70	3.40
York River R"24" to Port; to YRYC Mark "W"	1.70	5.10
YRYC Mark "W" to Port; to York River R"24"	1.70	6.80
Finish between R"24" and Committee Boat		

COURSE #11 (Spring/Fall) (6.0 Nautical Miles)	DISTANCE	CUM DIST
Start at York River R"24"; to Sarah Creek R"2"	1.08	1.08
Sarah Creek R"2" to Port; to Mark "A"	1.90	2.98
Mark "A" to Port; to York River R"24"	0.83	3.81
York River R"24" to Port; to Sarah Creek R"2"	1.08	4.89
Sarah Creek R"2" to Port; to York River R"24"	1.08	5.97
Finish between R"24" and Committee Boat		

COURSE #12 (Spring/Fall) (3.8 Nautical Miles)	DISTANCE	CUM DIST
Start at York River R"24"; to Sarah Creek R"2"	1.08	1.08
Sarah Creek "R2" to Port; to Mark "W"	1.02	2.10
Mark "W" to Port; to York River R"24"	1.70	3.80
Finish between R"24" and Committee Boat		

COURSE #13 (Spring/Fall) (3.4 Nautical Miles)	DISTANCE	CUM DIST
Start at York River R"24"; to "Quick Flash"	1.14	1.14
"Quick Flash" to Stbd; to Sarah Creek R"2"	1.18	2.32
Sarah Creek R"2" to Stbd; to York River R"24"	1.08	3.40
Finish between R"24" and Committee Boat		

YRYC Course Descriptions: SPRING SERIES and end of FALL SERIES

YRYC Course Descriptions: SPRING SERIES and end of FALL SERIES

COURSE #14 (Spring/Fall) (5.8 Nautical Miles)	DISTANCE	CUM DIST
Start at York River R"24"; to "Quick Flash"	1.14	1.14
"Quick Flash" to Stbd; to Sarah Creek R"2"	1.18	2.32
Sarah Creek R"2" to Stbd; to "Quick Flash"	1.18	3.50
"Quick Flash" to Stbd; to Sarah Creek R"2"	1.18	4.68
Sarah Creek R"2" to Stbd; to York River R"24"	1.08	5.76
Finish between R"24" and Committee Boat		

COURSE #15 (Spring/Fall) (3.8 Nautical Miles)	DISTANCE	CUM DIST
Start at York River R"24"; to Mark "W"	1.70	1.70
Mark "W" to Stbd; to Sarah Creek R"2"	1.02	2.72
Sarah Creek R"2" to Stbd; to York River R"24"	1.08	3.80
Finish between R"24" and Committee Boat		

COURSE #16 (Spring/Fall) (3.3 Nautical Miles)	DISTANCE	CUM DIST
Start at York River R"24"; to Mark "A"	0.83	0.83
Mark "A" to Port; to York River R"24"	0.83	1.66
York River R"24" to Port; to Mark "A"	0.83	2.49
Mark "A" to Port; to York River R"24"	0.83	3.32
Finish between R"24" and Committee Boat		

YRYC Course Descriptions: SPRING SERIES and end of FALL SERIES

YRYC Course Descriptions: SPRING SERIES and end of FALL SERIES

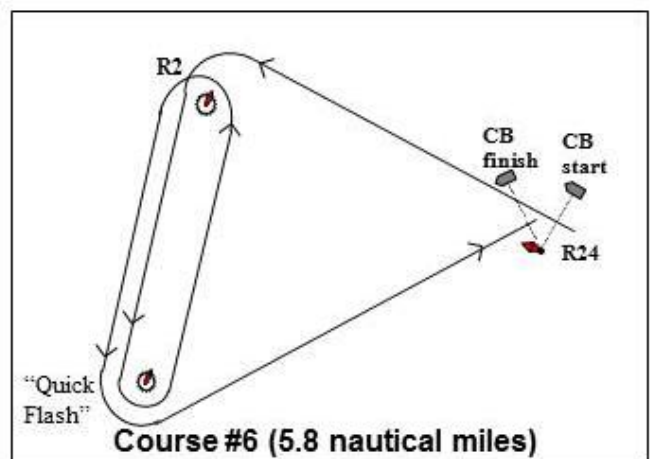
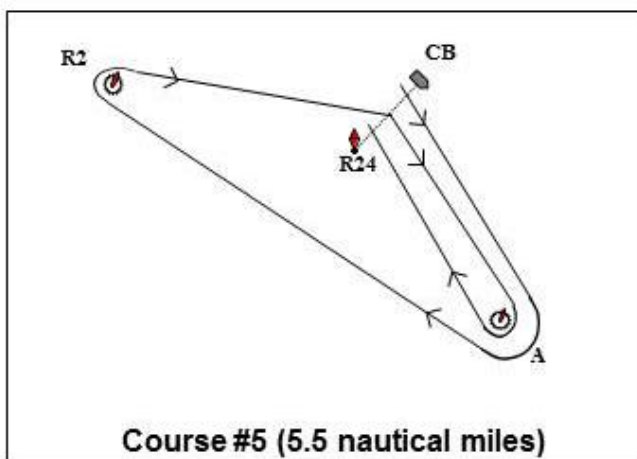
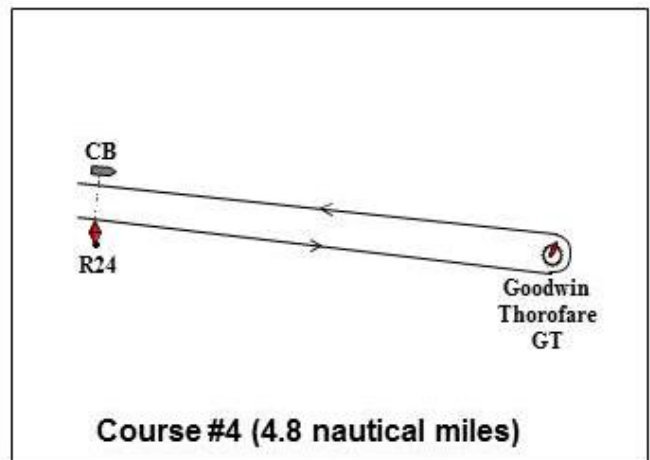
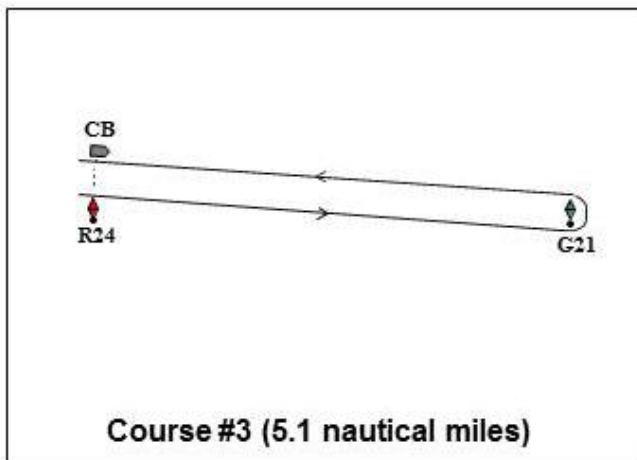
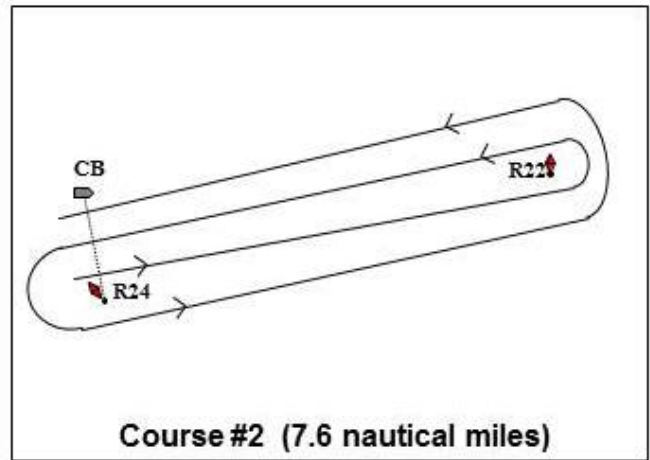
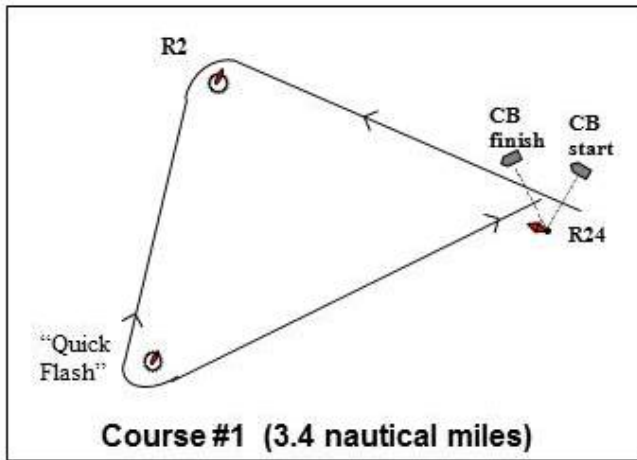

YRYC Course Descriptions: SPRING SERIES and end of FALL SERIES

YRYC Course Descriptions: SPRING SERIES and end of FALL SERIES

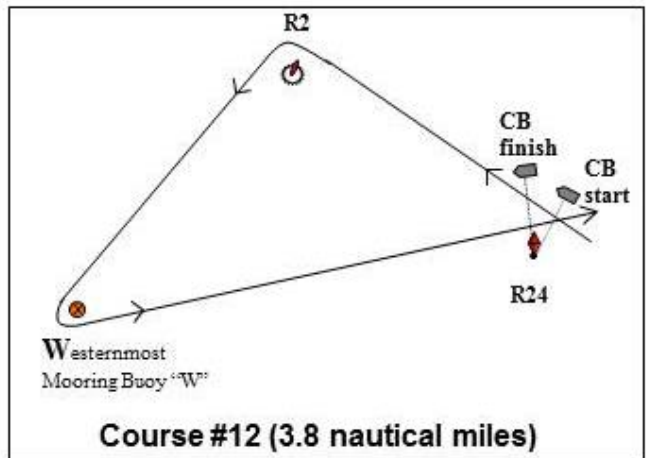
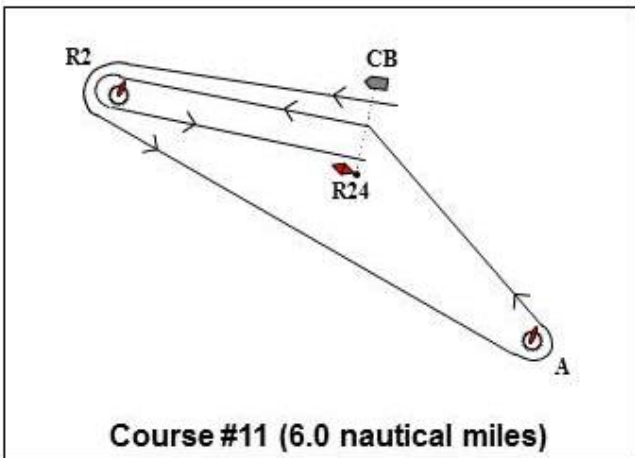
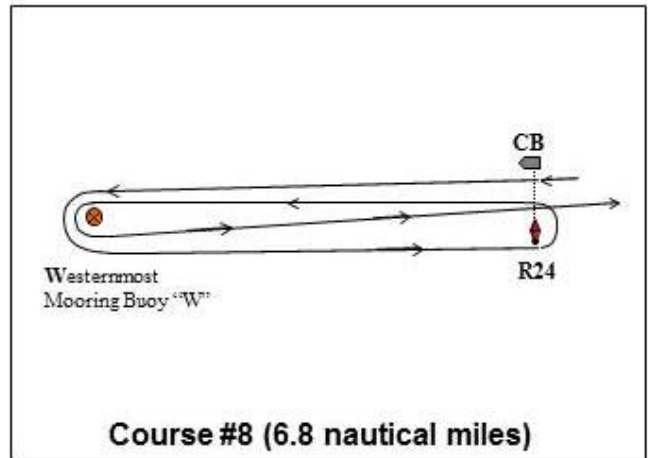
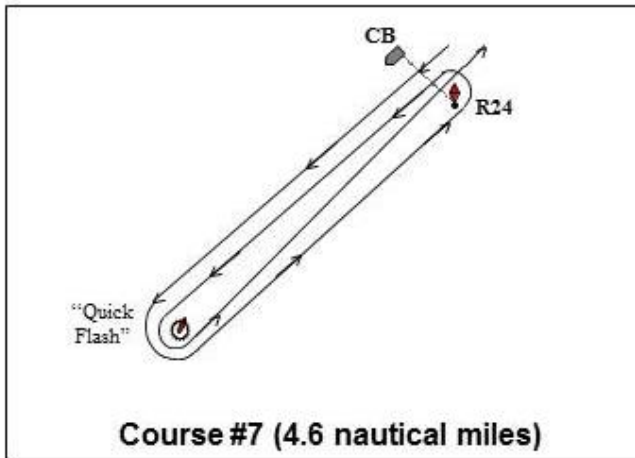

YRYC Course Descriptions: SPRING SERIES and end of FALL SERIES

YRYC Course Descriptions: SPRING SERIES and end of FALL SERIES

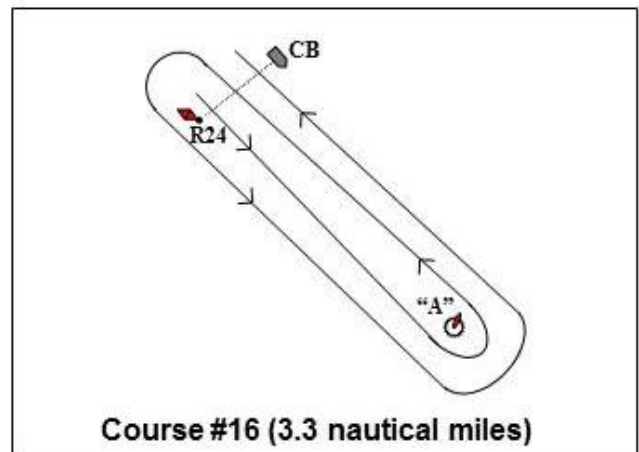
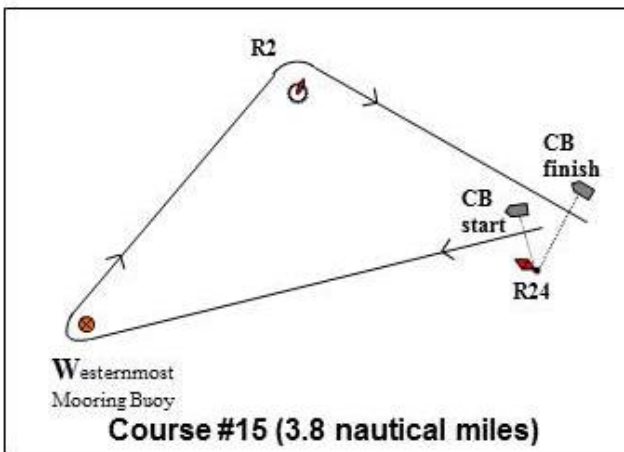
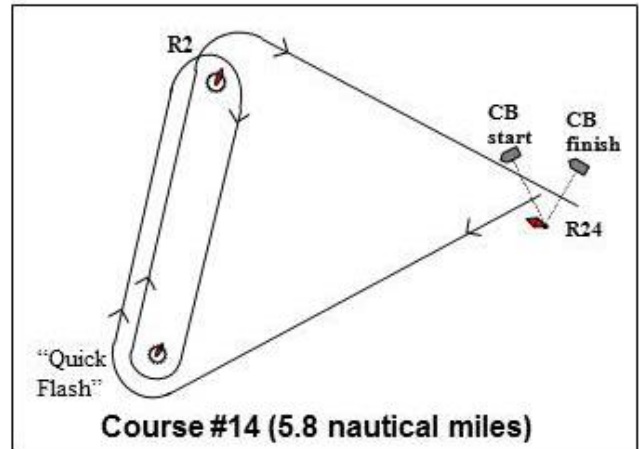
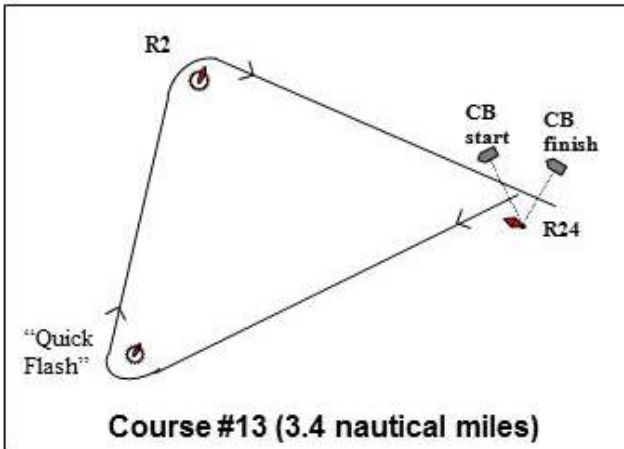

YRYC Course Descriptions: SPRING SERIES and end of FALL SERIES

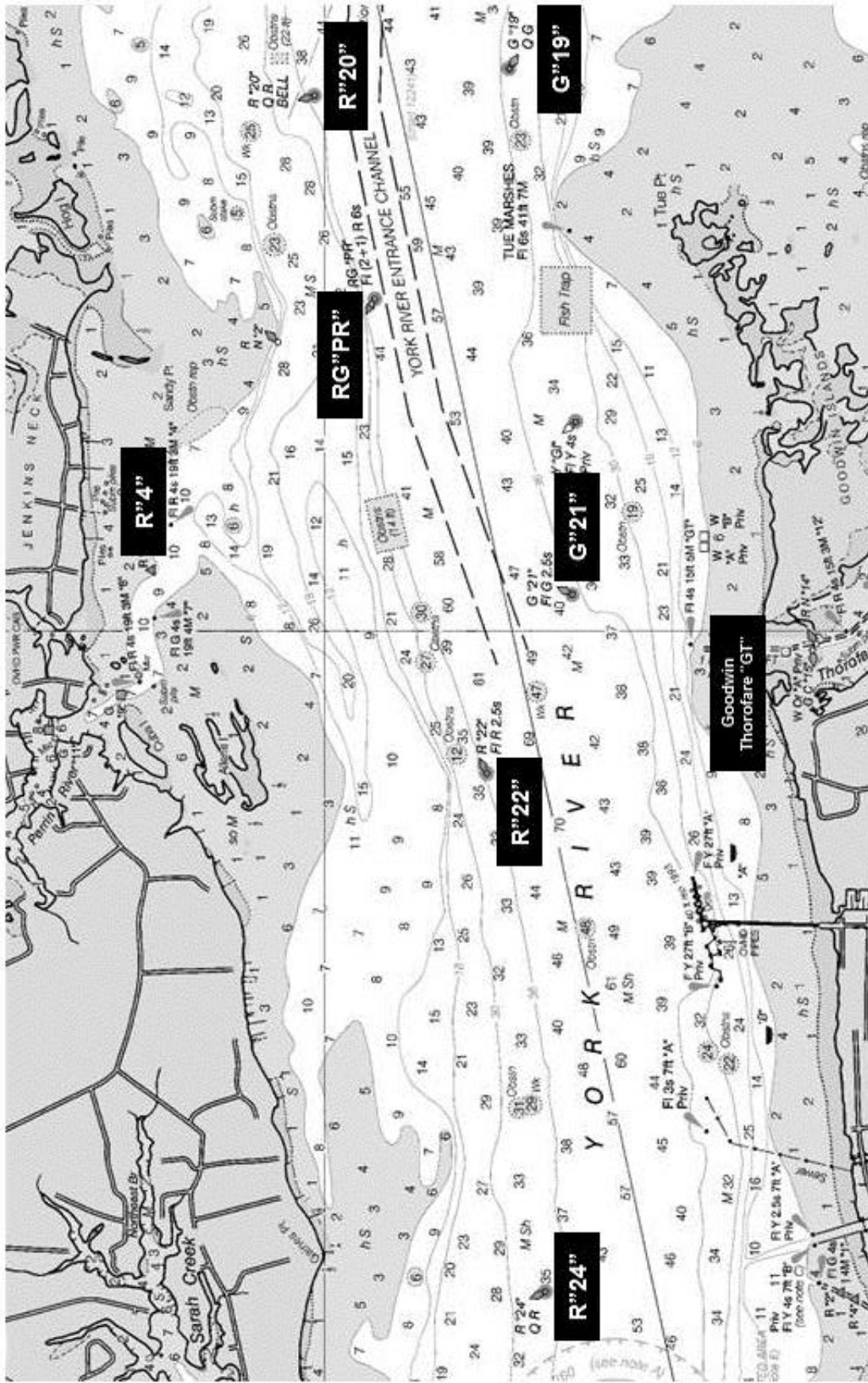

YRYC Race Area Chart for SUMMER, start of FALL, and FROSTBITE SERIES
 (NOT TO BE USED FOR NAVIGATION)

YRYC Course Descriptions: SUMMER, start of FALL and FROSTBITE SERIES

COURSE #1 (Summer/Frostbite) (7.3 NM)	DISTANCE	CUM DIST
Start at York River R"22"; to York River G"21"	0.72	0.72
York River G"21" to Port; to Perrin River R"4"	1.49	2.21
Perrin River R"4" to Port; to York River "R22"	1.46	3.67
York River "R22" to Stbd (CB to Port); to York River G"21"	0.72	4.39
York River G"21" to Port; to Perrin River R"4"	1.49	5.88
Perrin River R"4" to Port; to York River "R22"	1.46	7.34
Finish between R"22" and Committee Boat		

COURSE #2 (Summer/Frostbite) (5.8 NM)	DISTANCE	CUM DIST
Start at York River R"22"; to Perrin River R"4"	1.46	1.46
Perrin River R"4" to Port; to York River R"22"	1.46	2.92
York River R"22" to Port; to Perrin River R"4"	1.46	4.38
Perrin River R"4" to Port; to York River R"22"	1.46	5.84
Finish between R"22" and Committee Boat		

COURSE #3 (Summer/Frostbite) (7.0 NM)	DISTANCE	CUM DIST
Start at York River R"22"; to Perrin River "PR"	1.75	1.75
Perrin River "PR" to Port; to York River R"22"	1.75	3.50
York River R"22" to Port; to Perrin River "PR"	1.75	5.25
Perrin River "PR" to Port; to York River R"22"	1.75	7.00
Finish between R"22" and Committee Boat		

COURSE #4 (Summer/Frostbite) (6.2 NM)	DISTANCE	CUM DIST
Start at York River R"22"; to Mark "A"	1.54	1.54
Mark "A" to Port; to York River R"22"	1.54	3.08
York River "22" to Port; to Mark "A"	1.54	4.62
Mark "A" to Port; to York River R"22"	1.54	6.16
Finish between R"22" and Committee Boat		

COURSE #5 (Summer/Frostbite) (5.1 NM)	DISTANCE	CUM DIST
Start at York River R"22"; to York River R"20"	2.54	2.54
York River R"20" to Port; to York River R"22"	2.54	5.08
Finish between R"22" and Committee Boat		

YRYC Course Descriptions: SUMMER, start of FALL and FROSTBITE SERIES

YRYC Course Descriptions: SUMMER, start of FALL and FROSTBITE SERIES

COURSE #6 (Summer/Frostbite) (5.1 NM)	DISTANCE	CUM DIST
Start at York River R"22"; to York River G"19"	2.56	2.56
York River G"19" to Port; to York River R"22"	2.56	5.12
Finish between R"22" and Committee Boat		

COURSE #7 (Summer/Frostbite) (7.6 NM)	DISTANCE	CUM DIST
Start at York River R"22"; to York River R"24"	1.90	1.90
York River R"24" to Port; to York River R"22"	1.90	3.80
York River R"22" to Port; to York River R"24"	1.90	5.70
York River R"24" to Port; to York River R"22"	1.90	7.60
Finish between R"22" and Committee Boat		

COURSE #8 (Summer/Frostbite) (5.2 NM)	DISTANCE	CUM DIST
Start at York River R"22"; to York River G"21"	0.72	0.72
York River G"21" to Stbd; to York River R"24"	2.54	3.26
York River R"24" to Stbd; to York River R"22"	1.90	5.16
Finish between R"22" and Committee Boat		

COURSE #9 (Summer/Frostbite) (6.1 NM)	DISTANCE	CUM DIST
Start at York River R"22"; to Perrin River R"4"	1.46	1.46
Perrin River R"4" to Stbd; to York River G"19"	2.08	3.54
York River G"19" to Stbd; to York River R"22"	2.56	6.10
Finish between R"22" and Committee Boat		

COURSE #10 (Summer/Frostbite) (4.3 NM)	DISTANCE	CUM DIST
Start at York River R"22"; to Perrin River R"4"	1.46	1.46
Perrin River R"4" to Stbd; to Perrin River "PR"	1.10	2.56
Perrin River "PR" to Stbd; to York River R"22"	1.75	4.31
Finish between R"22" and Committee Boat		

COURSE #11 (Summer/Frostbite) (5.0 NM)	DISTANCE	CUM DIST
Start at York River R"22"; to Goodwin Thorofare "GT"	0.88	0.88
Goodwin Thorofare "GT" to Port; to Perrin River R"4"	1.94	2.82
Perrin River R"4" to Port; to York River G"21"	1.49	4.31
York River G"21" to Stbd; to York River R"22"	0.72	5.03
Finish between R"22" and Committee Boat		

YRYC Course Descriptions: SUMMER, start of FALL and FROSTBITE SERIES

YRYC Course Descriptions: SUMMER, start of FALL and FROSTBITE SERIES

COURSE #12 (Summer/Frostbite) (7.3 NM)	DISTANCE	CUM DIST
Start at York River R"22"; to Perrin River R"4"	1.46	1.46
Perrin River R"4" to Stbd; to York River G"21"	1.49	2.95
York River G"21" to Stbd; to York River R"22"	0.72	3.67
York River R"22" to Stbd; to Perrin River R"4"	1.46	5.13
Perrin River R"4" to Stbd; to York River G"21"	1.49	6.62
York River G"21" to Stbd; to York River R"22"	0.72	7.34
Finish between R"22" and Committee Boat		

COURSE #13 (Summer/Frostbite) (4.4 NM)	DISTANCE	CUM DIST
Start at York River R"22"; to York River G"21"	0.72	0.72
York River G"21" to Port; to Perrin River R"4"	1.49	2.21
Perrin River R"4" to Port; to York River G"21"	1.49	3.70
York River G"21" to Stbd; to York River R"22"	0.72	4.42
Finish between R"22" and Committee Boat		

COURSE #14 (Summer/Frostbite) (2.9 NM)	DISTANCE	CUM DIST
Start at York River R"22"; to York River G"21"	0.72	0.72
York River G"21" to Port; to York River R"22"	0.72	1.44
York River R"22" to Port; to York River G"21"	0.72	2.16
York River G"21" to Port; to York River R"22"	0.72	2.88
Finish between R"22" and Committee Boat		

COURSE #15 (Summer/Frostbite) (5.3 NM)	DISTANCE	CUM DIST
Start at York River R"22"; to York River R"20"	2.54	2.54
York River R"20" to Stbd; to York River G"21"	2.04	4.58
York River G"21" to Stbd; to York River R"22"	0.72	5.30
Finish between R"22" and Committee Boat		

COURSE #16 (Summer/Frostbite) (6.0 NM)	DISTANCE	CUM DIST
Start at York River R"22"; to Mark "A"	1.54	1.54
Mark "A" to Stbd; to York River R"22"	1.54	3.08
York River R"22" to Stbd (CB to Port); to Perrin River R"4"	1.46	4.54
Perrin River R"4" to Port; to York River R"22"	1.46	6.00
Finish between R"22" and Committee Boat		

YRYC Course Descriptions: SUMMER, start of FALL and FROSTBITE SERIES

YRYC Course Descriptions: SUMMER, start of FALL and FROSTBITE SERIES

COURSE #17 (Summer/Frostbite) (7.1 NM)	DISTANCE	CUM DIST
Start at York River R"22"; to Perrin River R"4"	1.46	1.46
Perrin River R"4" to Stbd; to York River G"19"	2.08	3.54
York River G"19" to Stbd; to Perrin River R"4"	2.08	5.62
Perrin River R"4" to Port; to York River R"22"	1.46	7.08
Finish between R"22" and Committee Boat		

COURSE #18 (Summer/Frostbite) (5.1 NM)	DISTANCE	CUM DIST
Start at York River R"22"; to Perrin River R"4"	1.46	1.46
Perrin River R"4" to Stbd; to Perrin River "PR"	1.10	2.56
Perrin River "PR" to Stbd; to Perrin River R"4"	1.10	3.66
Perrin River R"4" to Port; to York River R"22"	1.46	5.12
Finish between R"22" and Committee Boat		

COURSE #19 (Summer/Frostbite) (4.1 NM)	DISTANCE	CUM DIST
Start at York River R"22"; to York River G"21"	0.72	0.72
York River G"21" to Stbd; to Goodwin Thorofare "GT"	0.47	1.19
Goodwin Thorofare "GT" to Stbd; to York River R"22"	0.88	2.07
York River R"22" to Stbd; to York River G"21"	0.72	2.79
York River G"21" to Stbd; to Goodwin Thorofare "GT"	0.47	3.26
Goodwin Thorofare "GT" to Stbd; to York River R"22"	0.88	4.14
Finish between R"22" and Committee Boat		

COURSE #20 (Summer/Frostbite) (4.1 NM)	DISTANCE	CUM DIST
Start at York River R"22"; to Goodwin Thorofare "GT"	0.88	0.88
Goodwin Thorofare "GT" to Port; to York River G"21"	0.47	1.35
York River G"21" to Port; to York River R"22"	0.72	2.07
York River R"22" to Port; to Goodwin Thorofare "GT"	0.88	2.95
Goodwin Thorofare "GT" to Port; to York River G"21"	0.47	3.42
York River G"21" to Port; to York River R"22"	0.72	4.14
Finish between R"22" and Committee Boat		

YRYC Course Descriptions: SUMMER, start of FALL and FROSTBITE SERIES

YRYC Course Descriptions: SUMMER, start of FALL and FROSTBITE SERIES

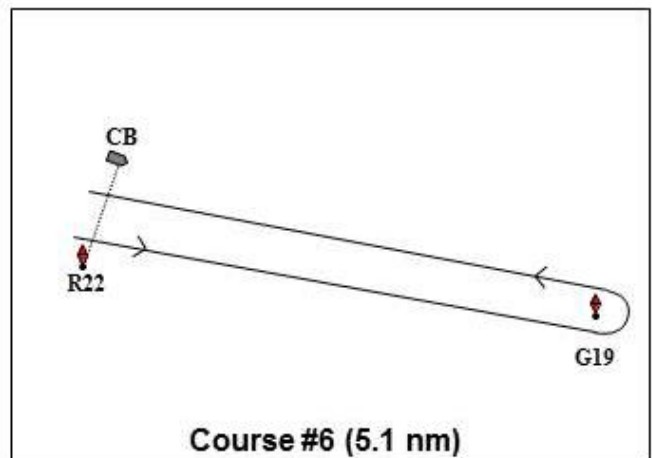
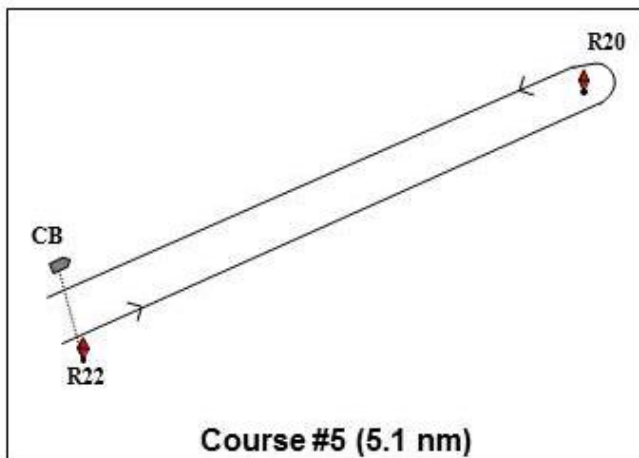
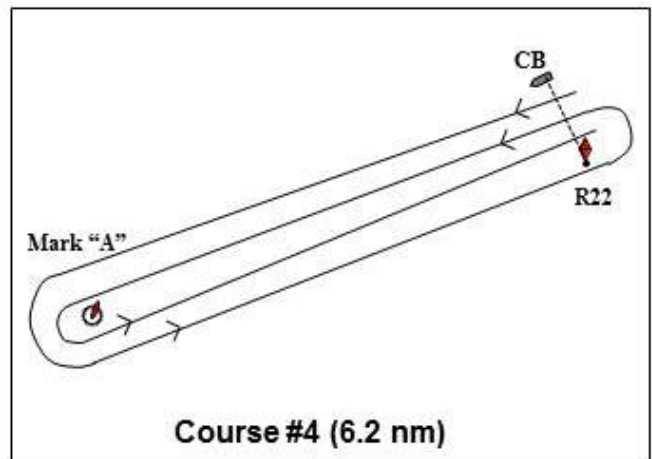
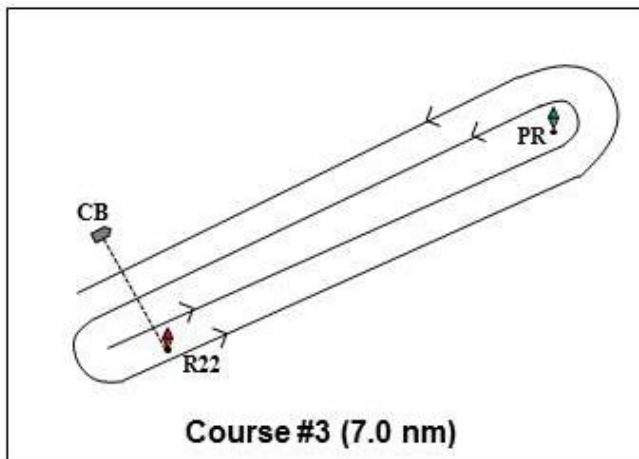
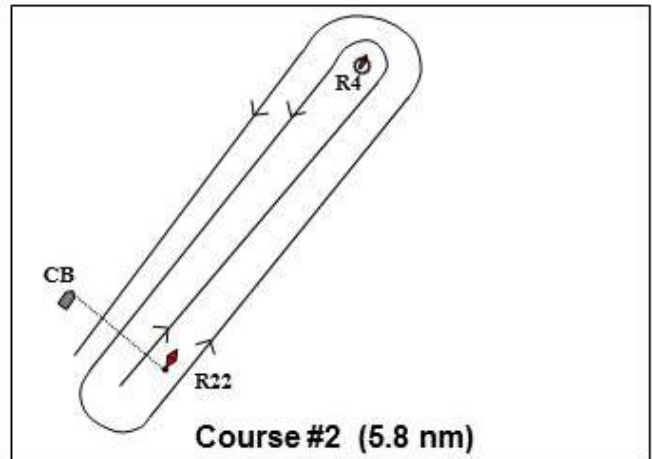
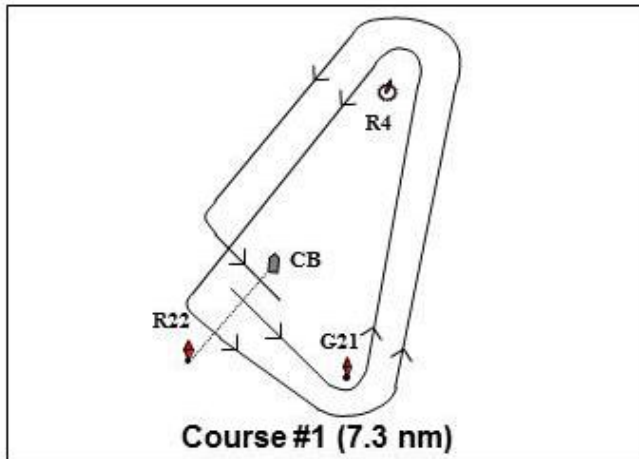

YRYC Course Descriptions: SUMMER, start of FALL and FROSTBITE SERIES

YRYC Course Descriptions: SUMMER, start of FALL and FROSTBITE SERIES

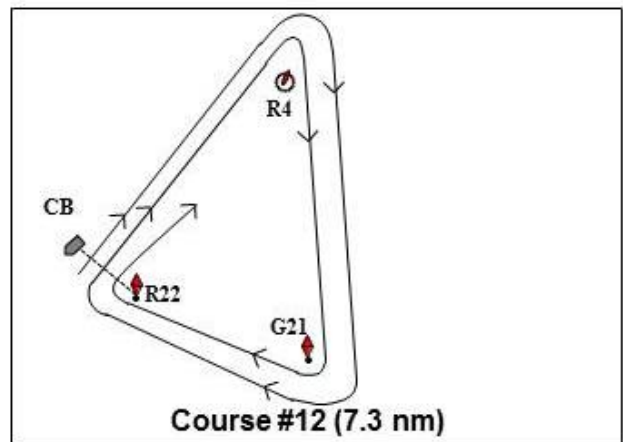
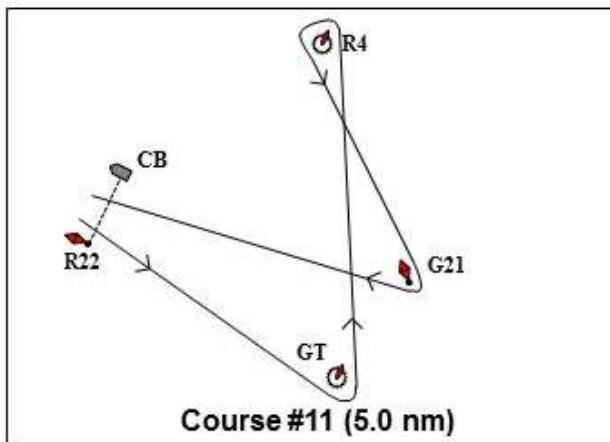
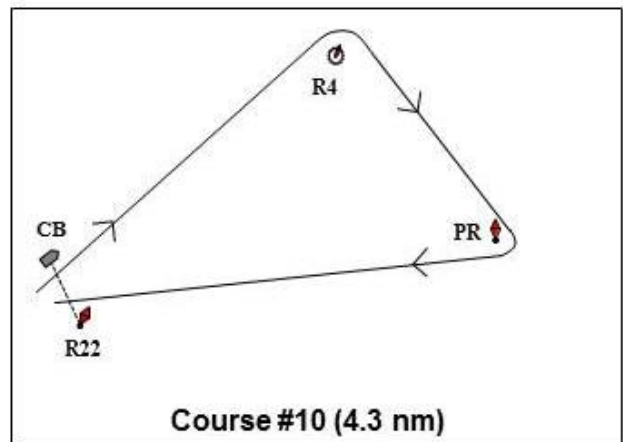
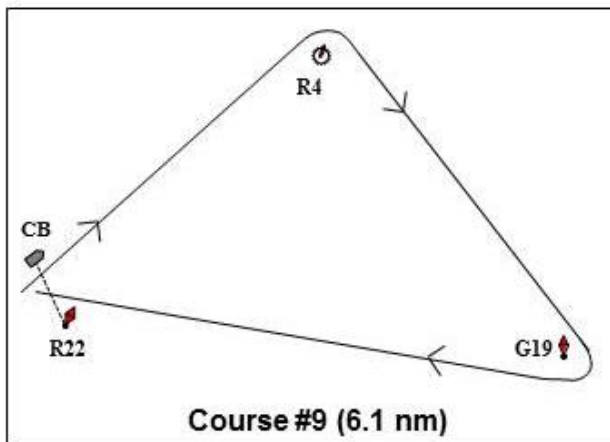
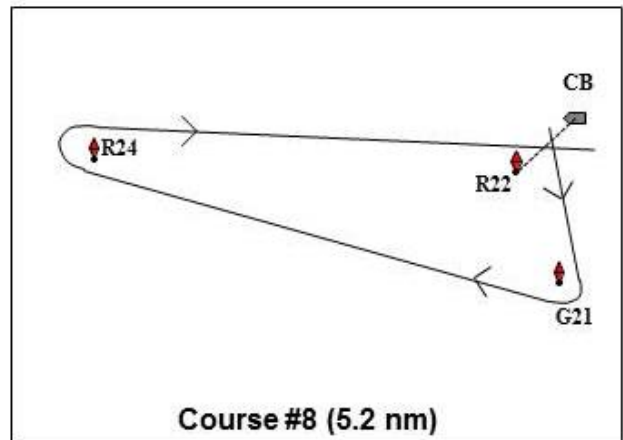
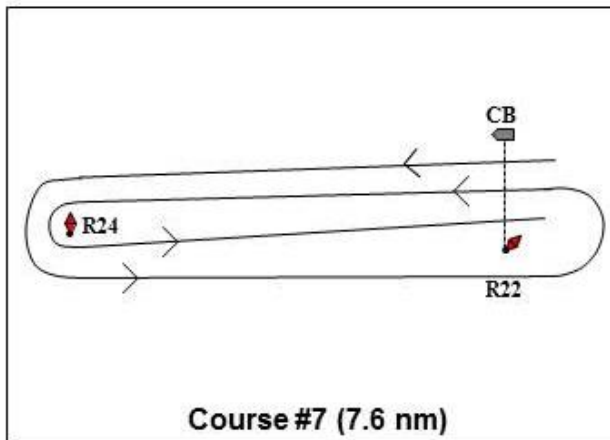

YRYC Course Descriptions: SUMMER, start of FALL and FROSTBITE SERIES

YRYC Course Descriptions: SUMMER, start of FALL and FROSTBITE SERIES

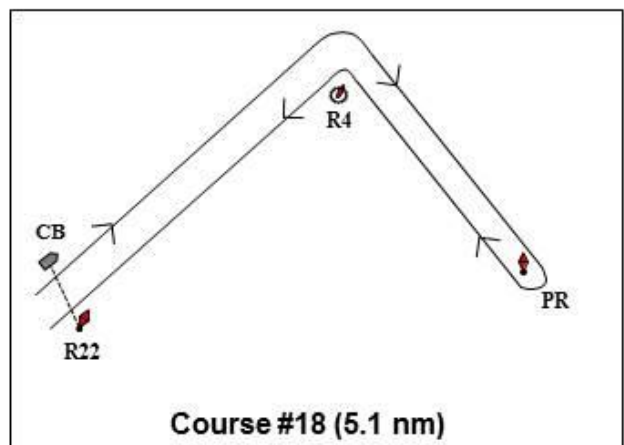
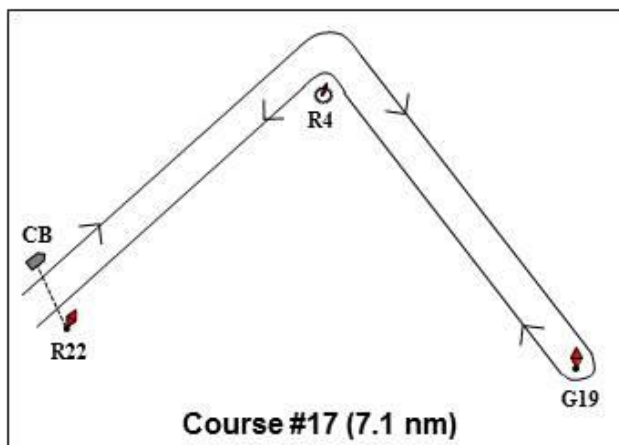
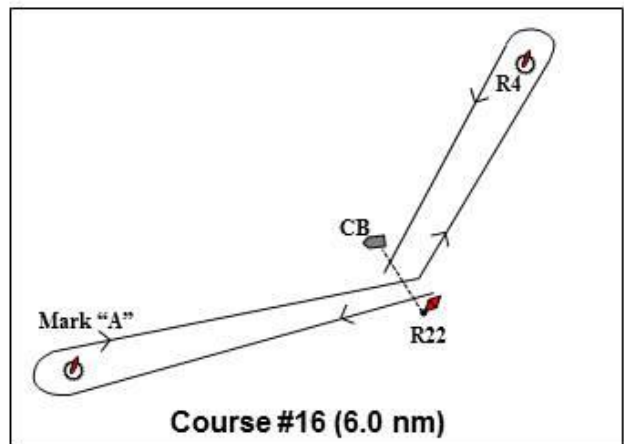
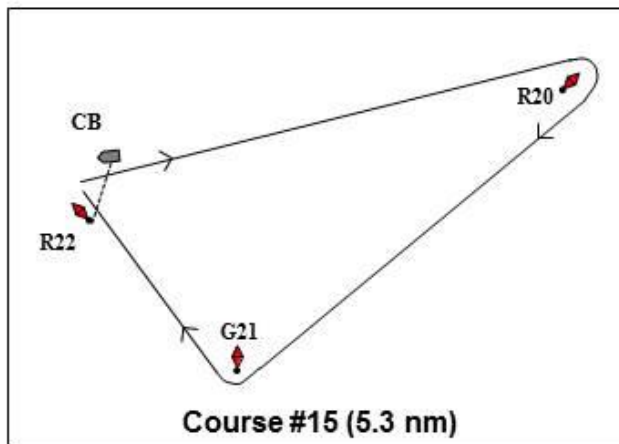
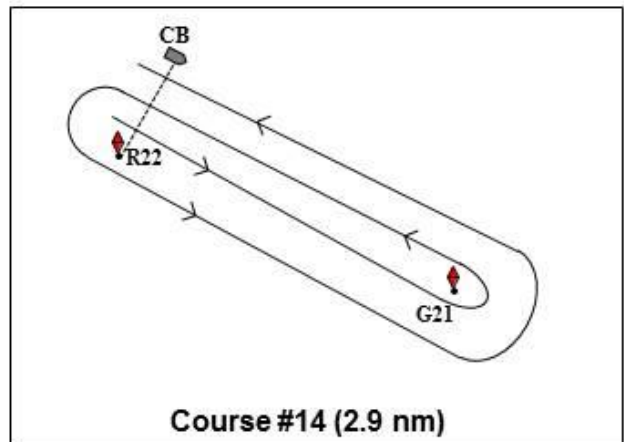
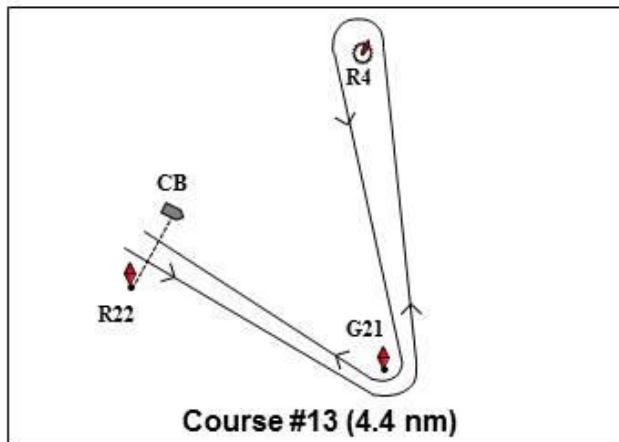

YRYC Course Descriptions: SUMMER, start of FALL and FROSTBITE SERIES

YRYC Course Descriptions: SUMMER, start of FALL and FROSTBITE SERIES

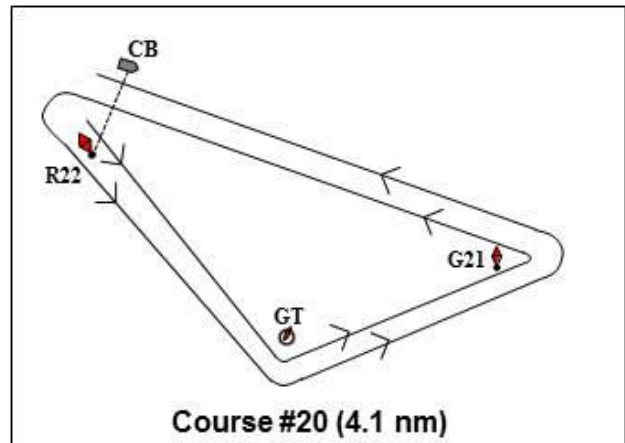
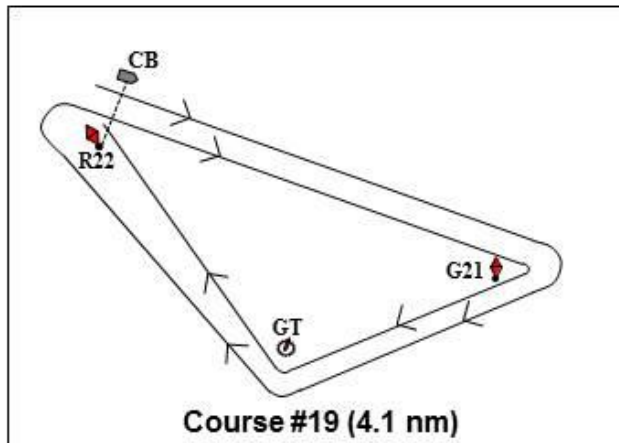

YRYC Course Descriptions: SUMMER, start of FALL and FROSTBITE SERIES

THIS SIDE FOR PROTEST COMMITTEE USE

Number _____ Heard together with numbers _____

Fill in and tick as appropriate

Withdrawal requested ; signed _____ Withdrawal permitted

Protest time limit _____

Protest, or request for redress or reopening, is within time limit

Time limit extended

Protestor, or party requesting redress or reopening, represented by _____

Other party, or boat being considered for redress, represented by _____

Names of witnesses _____

Interpreters _____

REMARKS

Objection about interested party _____

Written protest or request identifies incident _____

'Protest' hailed at first reasonable opportunity _____

No hail needed, protestee informed at first reasonable opportunity _____

Red flag conspicuously displayed at first reasonable opportunity _____

Red flag seen by race committee at finish _____

Protest or request valid, hearing will continue Protest or request invalid, hearing is closed

FACTS FOUND _____

Diagram of boat _____ is endorsed by committee

Committee's diagram is attached

CONCLUSIONS AND RULES THAT APPLY _____

DECISION

Protest is dismissed

Boat(s) _____ is (are) disqualified ;

penalized as follows : _____

Redress is not given ; given as follows : _____

Request to reopen a hearing is denied ; granted

Protest committee chairman and other members _____

Chairman's signature _____ Date and time _____

APPENDIX B: Race Entry Forms

	CBYRA STANDARD ENTRY FORM	CLASS _____	EVENT TITLE _____	EVENT SANCTION NUMBER _____
Sail #	Name of Yacht	CBYRA* Member #	Yacht Club*	US Sailing Member #
Competitor: _____ email _____				
Address: _____				
Phone: Home _____ Office _____ Cell _____				
Class Information		<i>I certify that this yacht conforms in every way to Class Rules and Measurements. For PHRF, a copy of my most recent Handicap Rating certificate (or valid listing) is attached to this entry form. For other classes, any applicable certification is on file with the Class Representative, Host Club, or attached to this entry form (initial one):</i> YES _____ NO _____		
One-Design _____ PHRF _____ Rating: _____		Class to be entered (circle one) MORC _____ Multihull _____ Other _____		
Hull Color: _____		Crew: _____ Make & Model: _____		
<i>I agree to abide by 1) the Racing Rules of Sailing (RRS), 2) Either the General Sailing Instructions published by CBYRA OR Event Sailing Instructions published by the Host Club, and 3) other rules that govern this event. In consideration of being permitted to enter this event, being knowledgeable of the risks of competitive sailing and knowing that it is my sole responsibility to decide whether to enter or continue any race, I voluntarily assume the risk of participation in this event and release Host Club _____ and the people conducting the event, from all liability in connection with any injury or damage that may occur.</i>				
Signature of Competitor _____ Date _____				
*NOTE: Membership in CBYRA, Class Association, and an affiliate yacht club are required PRIOR to earning any points toward CBYRA High Point Trophies. Failure to do so may cause rejection of entry.				



York River Yacht Club Entry Form For Wednesday Night Races



Boat Name:	Mfgr/Model:	
Competitor's Name:	Complete this section to receive YRYC adjusted handicap rating	
Address:	Furling Drum Placement: Below Deck <input type="checkbox"/> Above Deck <input type="checkbox"/>	
	Prop: Fldg/Feathered <input type="checkbox"/> Fixed 2-blade <input type="checkbox"/> Fixed 3-blade <input type="checkbox"/>	
	Size of largest Genoa: Up to 140% <input type="checkbox"/> 141%-148% <input type="checkbox"/>	
	149%-155% <input type="checkbox"/> 156%-163% <input type="checkbox"/> 164%-170% <input type="checkbox"/> Over 170% <input type="checkbox"/>	
Email:	Weight (Mfgr's Spec) _____ Sail Area (100% Foresail) _____	
Home Phone: () _____ Business Phone: () _____	Currently Assigned PHRF Handicap Number _____	
I agree to abide by the regulations and sailing instructions for this event. In consideration of being permitted to enter this event, being knowledgeable of the risks of competitive sailing and knowing that it is my sole responsibility to decide to enter or continue any race, I voluntarily assume the risk of participation in this event and release YRYC and the people conducting the event from all liability in connection with any injury or damage that may occur. Competitor warrants that his/her participating yacht meets the minimum CBYRA safety requirements applicable at the submission of this entry form.	RACE CAPTAIN TO COMPLETE SECTION BELOW	
	Adjustment for Propeller Configuration	
	Adjustment for Genoa Drum Placement	
	Adjustment for Size of Largest Genoa	
	Adjusted Handicap for YRYC Wednesday Night Races	
Signature: _____	Date: _____	

APPENDIX C: YRYC 2015 RACE SCHEDULE

Wednesday Night Racing

Registration Dinner: April 1, 6:30pm YRYC Club Room at Crown Pointe Marina

Practice Race: April 8

Spring Series

April 15, 22, 29

May 6, 13, 20, 27

Makeup date is June 3, if needed

Summer Series

June 10, 17, 24

July 1, 8, 15, 22

Makeup date is July 29, if needed

Fall Series

August 5, 12, 19, 26

September 2, 9

Makeup date is September 16, if needed

Frostbite Series Racing

October 11, 18, 25

November 1, 8

YRYC Special Races

YRYC Moonlight Race: August 1

YRYC Single Hand Race: TBD

YRYC York River Cup: September 12

YRYC Racing Awards Dinner: December 2, 6:30pm at YRYH Activities Room

Southern Bay Races outside YRYC

Down the Bay Race: May 22 - 23

Southern Bay Race Week: May 29 - 31

Cock Island Race: June 19 - 20

So. Ches. Bay Leukemia Regatta: July 11 - 12

Sunfish Challenge: September 19

Turkey Shoot Regatta: October 3 - 4

Complete Southern Bay Schedule: <http://www.ccvracing.org/Racing/racing.html>